

Welcome to

**DESIGNCON<sup>®</sup> 2026**  
**WHERE THE CHIP MEETS THE BOARD**

**Conference**

February 24–26, 2026  
Santa Clara Convention Center

**Expo**

February 25–26, 2026



# A Hybrid System-Level Modeling and Sensitivity Analysis Approach to Improve IC Immunity for Inductive Position Sensors in Noisy Automotive Environment

Speaker: Bhuvan Sai Lingam, (Simyog Technology Pvt. Ltd.)

*Authors:*

*Bhuvan Sai Lingam (Simyog Technology Pvt. Ltd.)*

*Ganesh Shaga (Microchip India Technology Pvt. Ltd.)*

*Mark Smith (Microchip Technology Inc.)*

*Bibhu Prasad Nayak (Simyog Technology Pvt. Ltd.)*



# Speaker



## Bhuvan Sai Lingam

*Application Engineer, Simyog Technology Pvt. Ltd.*  
bhuvan@simyog.com | simyog.com

**Bhuvan Sai Lingam** received his Bachelor of Technology degree in Electronics and Communications from Amrita Vishwa Vidyapeetham, Coimbatore, Tamil Nadu, India, in 2022, and received his Master of Science degree in Electrical Engineering (Applied Electromagnetics) from the University of California, San Diego, USA, in 2024. He currently works at SimYog Technology Pvt. Ltd., Bengaluru, India, as an Application Engineer dedicated to solving automotive EMI/EMC issues.



# Automotive EMC Compliance



# Proliferation of Automotive Electronics

- Automotive electronics refers to electronic systems and components in vehicles for various purposes.
- Electronics is at the heart of the automotive industry → “**future of mobility**”.
- The global automotive electronics market size estimate: **USD 307.61 billion (2025)**, predicted to hit ~ **USD 647.43 billion (2034)**.
- What are the key **drivers** of this market?

Precedence  
RESEARCH

Automotive Electronics Market Size 2025 to 2034 (USD Billion)

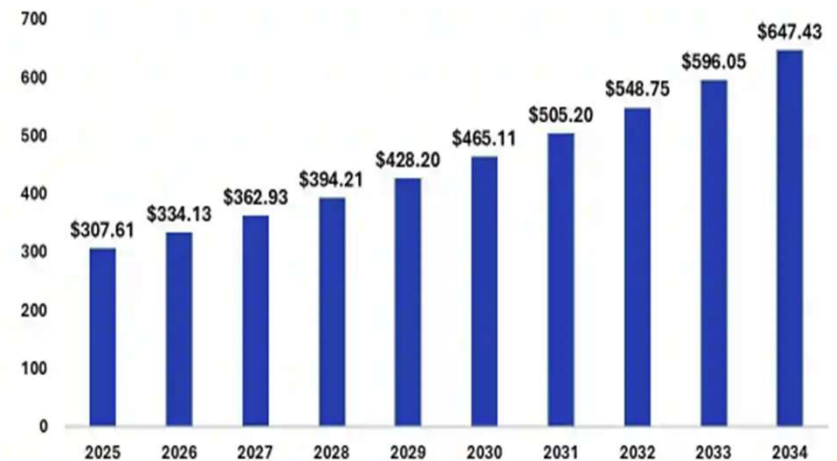

**Source:** <https://www.precedenceresearch.com/automotive-electronics-market>



# Drivers of Automotive Electronics



## Hybrid and electric vehicle powertrain systems

Enabling longer distances between charges, higher performance and safer, more affordable vehicles

## Advanced driver assistance systems

Creating a safer driving experience while building the foundation for the fully autonomous vehicle

## Infotainment and cluster

Making the driving experience smarter and safer through advanced display communication and connectivity capabilities

## Body electronics and lighting

Optimizing comfort and convenience in and around the vehicle with innovative analog and embedded processors



*Source: Slide from Rajen Murugan, IEEE EDAPS 2024*



# Automotive Systems - Safety Critical

UPDATE: Toyota Documents Show EMI as Possible Root of Sudden Acceleration Problem

Automotive, News

**Honda Australia Recalls Accord Sport Hybrid due to EMI**

In Compliance News

IEEE SPECTRUM

**Electronic Noise Is Drowning Out the Internet of Things**

Our increasingly connected world needs better protection against RF noise pollution

- Immunity to EMI has become a serious aspect of automotive testing, with conformance to standards mandated in most countries in the world.
- To comply with the current quality standards of the automotive industry, IC suppliers will need to adhere to more stringent EMC standards.



# EMC Modeling Requirement



# High “First-Pass” Failure Rates in EMI/EMC Compliance Testing

- Intertek Testing Services reports that many products fail EMC testing on the first attempt.
  - 1<sup>st</sup> Eval: 50% fail
  - 2<sup>nd</sup> Eval: 5-7% fail
  - 3<sup>rd</sup> Eval: 1-2% fail
- A second Intertek report states “**Over 90% of electrical medical devices that Intertek has tested have failed to comply with the required standards in the first submission**”, with the primary cause attributed to EMC-related test failures.

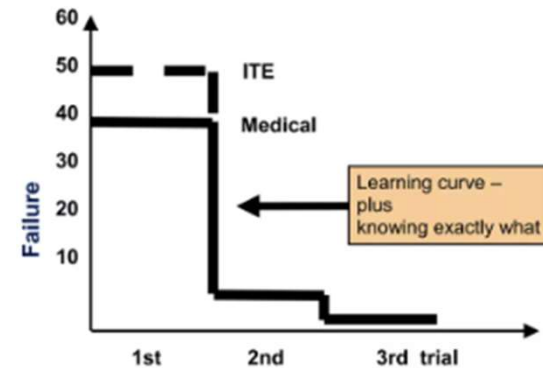

*Source: Interetek - Why 50% of Products Fail EMC Testing the First Time*



# EMC Modeling Requirement

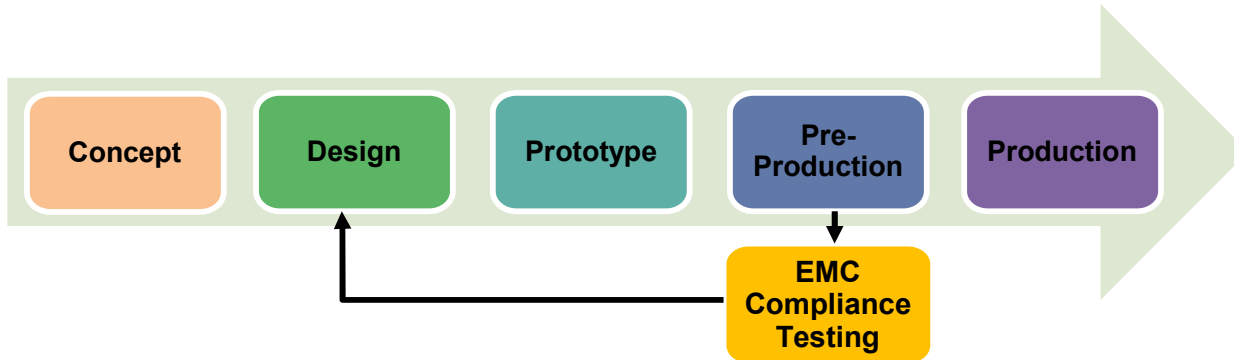

## Traditional Design Flow

- Multiple design fabrications
- Increased time to market
- Longer design cycle

## Optimized Design Flow

- First-time design success
- Shorter design cycle
- Financial/business benefits

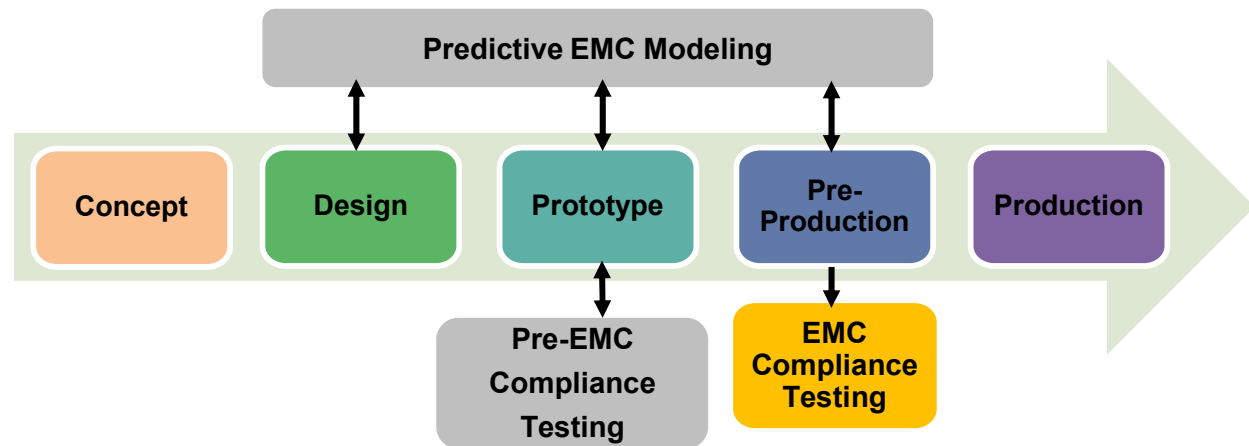

# EMC Compliance Tests

## Electromagnetic Compliance Testing

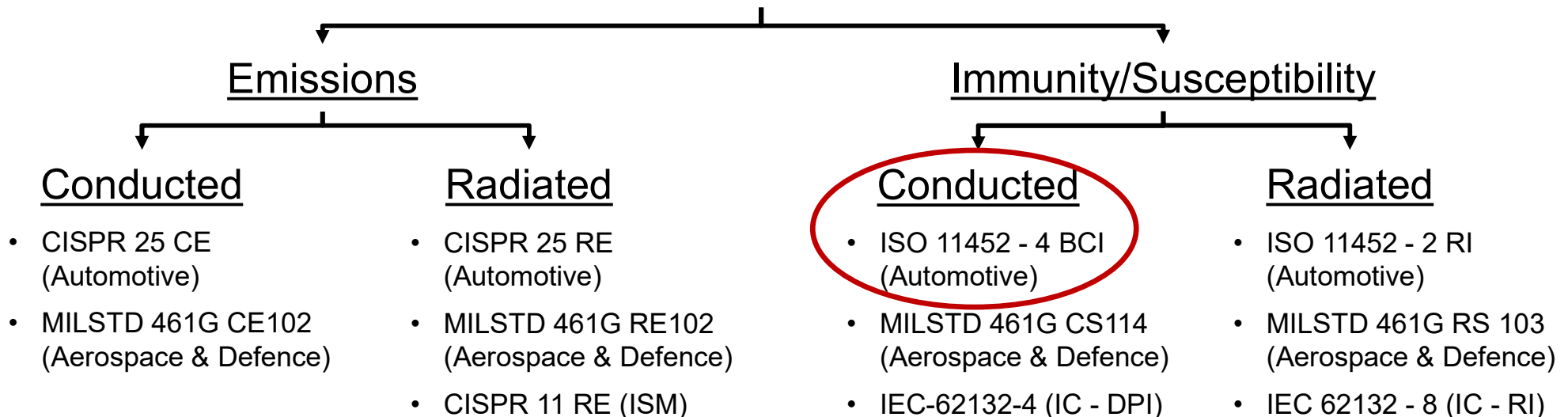

- Electromagnetic immunity testing assesses the susceptibility of vehicle electronics to externally coupled interference.
- Bulk Current Injection (BCI) test evaluates conducted immunity along wiring harnesses, serving as a critical method for automotive compliance validation.



# Simulation Methodology: BCI



# BCI Test (ISO 11452-4 Open Loop)

- Components of a BCI test
  - DUT (Device Under Test)
  - Injection & Monitor Clamp
  - Signal Generator
  - Harness
  - LISN (Line Impedance Stabilization Network)
  - Table
- A common-mode disturbance is injected into the cable harness and the DUT's immunity to conducted electromagnetic disturbances is assessed.
- During BCI, the common mode to differential mode conversion arises due to asymmetries in parasitic layout, slight mismatch in stray capacitance, inductance, trace geometry, ground return path, etc.
- Failures might occur due to resonances caused by these parasitics.

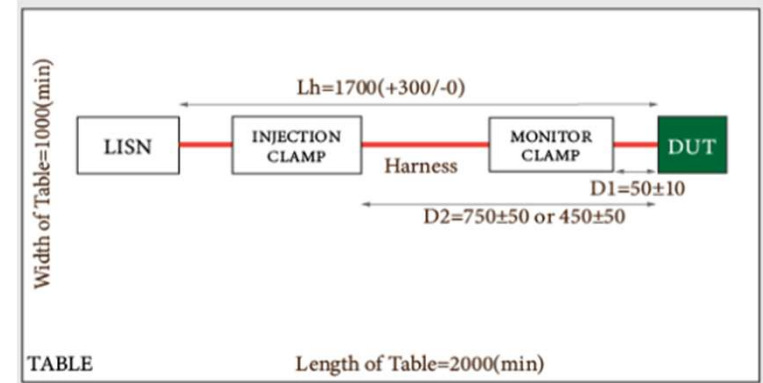
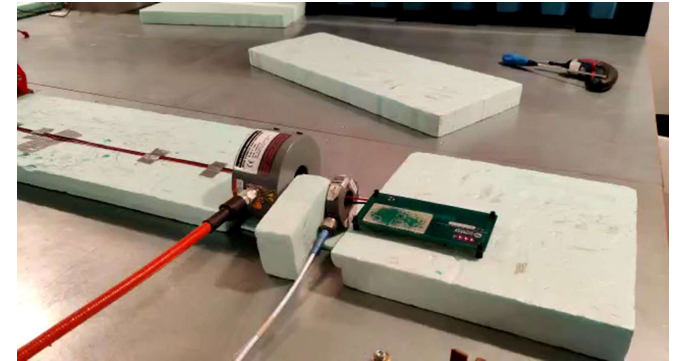

# BCI Modeling Flow

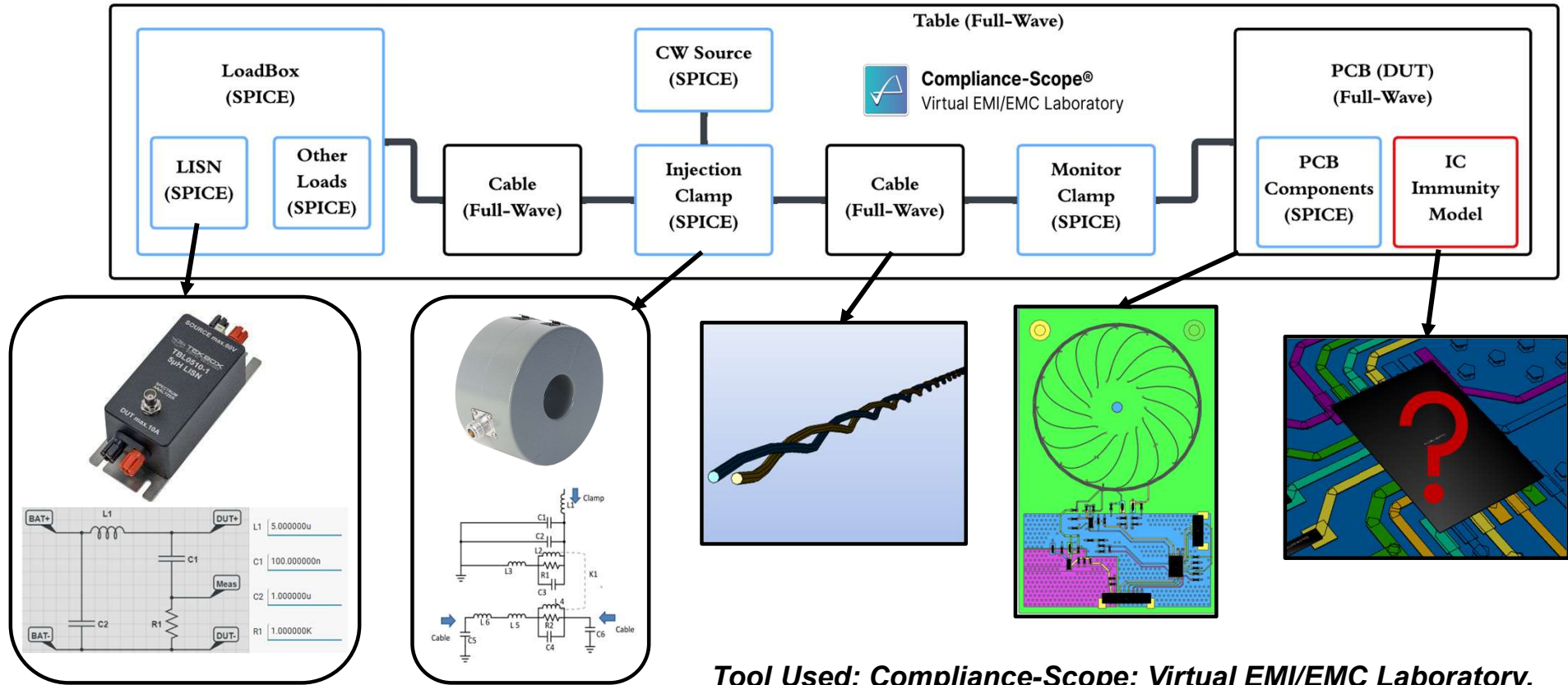

**Tool Used: Compliance-Scope: Virtual EMI/EMC Laboratory, 3D Full wave EM and circuit level network co-simulation.**



# IC Modeling: DPI Test (IEC 62132-4)

- RF disturbance is directly injected into individual IC pins using coupling networks.
- It evaluates IC immunity to conducted RF EMI ranging from 150 kHz up to 1 GHz.
- Pin-selective testing approach monitors IC degradation or complete malfunction under swept frequency and increasing power levels.
- Power Failure Threshold
  - Power Failure Levels vs Frequency curves are measured for IC pins (at the SMA connector).
- IC Pin Impedance
  - The S11 of individual IC pins are measured at the SMA connector using a VNA.

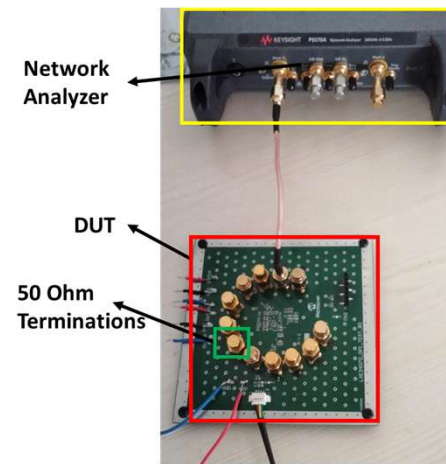
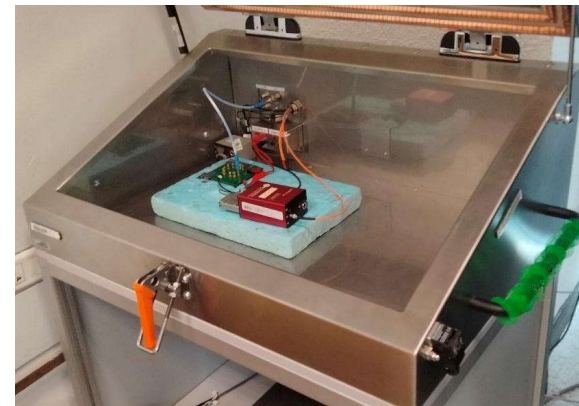
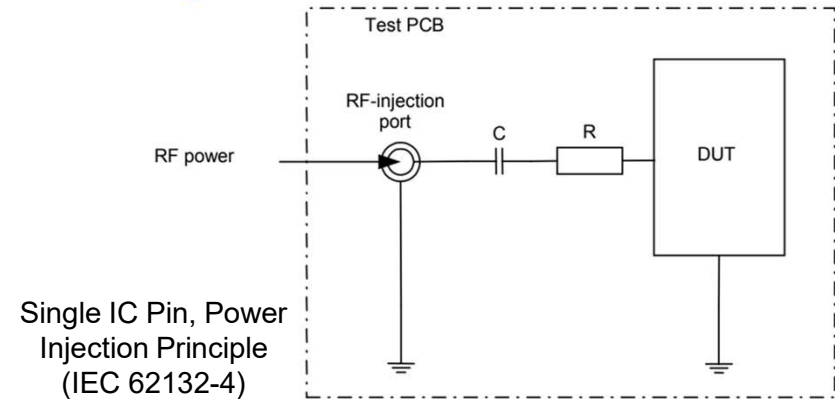

# IC Modeling: IC Immunity Model (IEC 62433-4)

- ICIM comprises of two parts:
  - PDN (Passive Distribution Network): Describes the impedance network of an IC at its pins. Represented as an S-param model.
    - *It is calculated by de-embedding the coupling network and the PCB trace from the VNA measurement.*
  - IB (Immunity Behavior): Shows the voltage immunity behavior/voltage threshold of the respective IC pin.
    - *It is calculated by de-embedding the coupling network S-parameters to the IC pin reference plane from the power failure data measured at the SMA connector.*

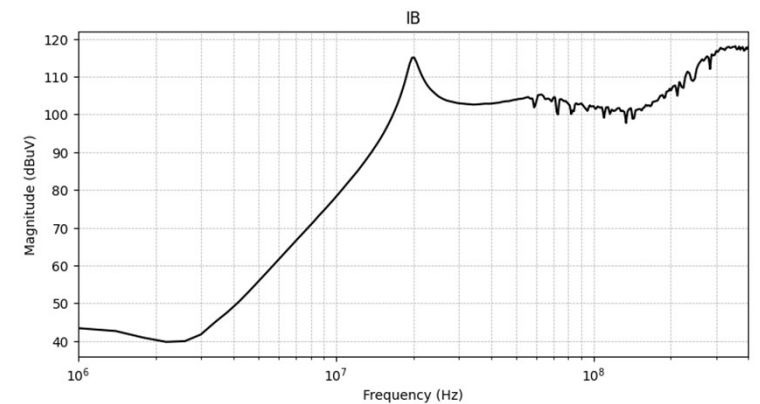
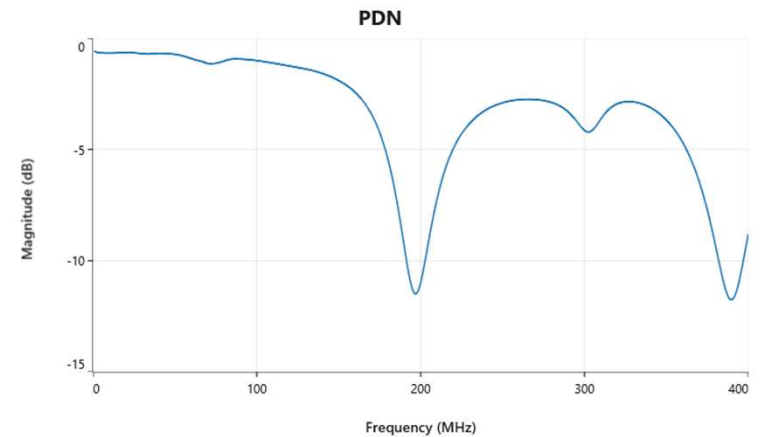

# BCI: Inductive Position Sensors



# Introduction

- Inductive position sensors generate alternating magnetic field using transmitter coil to detect target position.
- Conductive targets induce eddy currents, creating secondary magnetic fields that interact with primary field.
- Secondary fields modify coil impedance, which is analyzed to compute target position with high accuracy.
- Inductive position sensors are used in automotive throttle valves, EGR valves, and pedal position sensing applications.
- EMC compliance is critical to ensure reliable operation amid harsh electromagnetic environments in automotive systems.

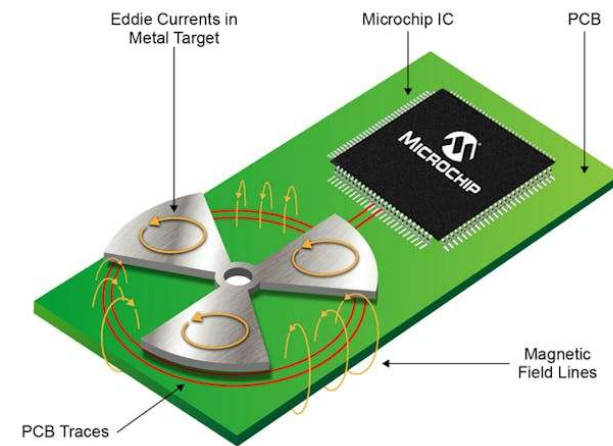
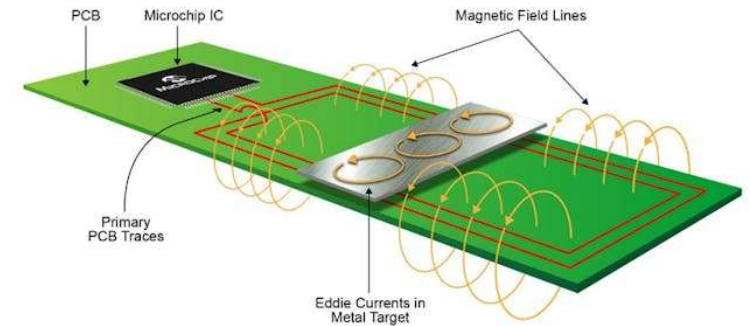

# Virtual Lab Setup: Device Under Test (DUT)

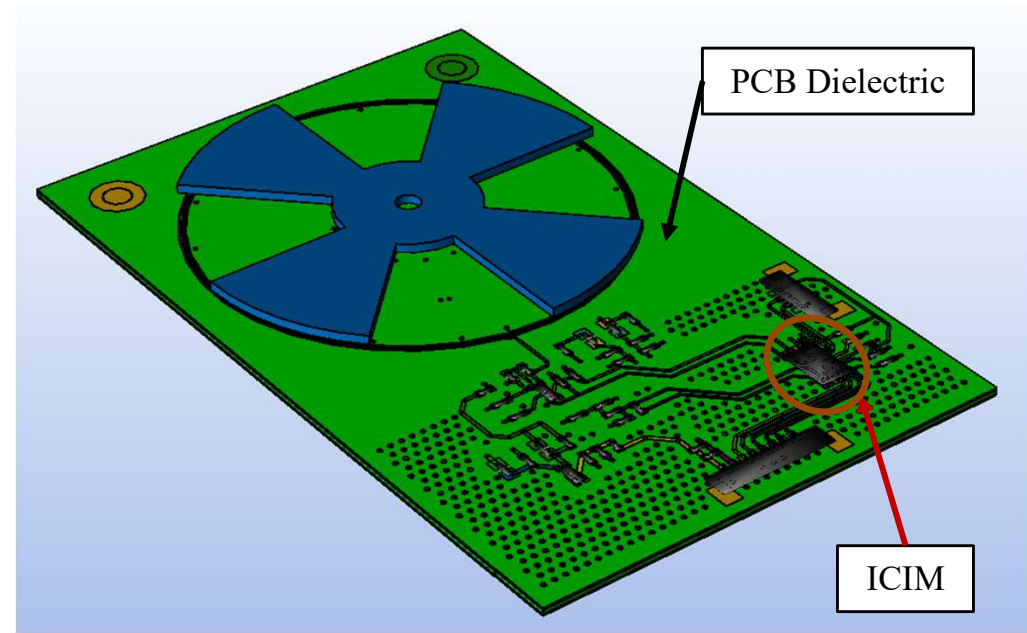
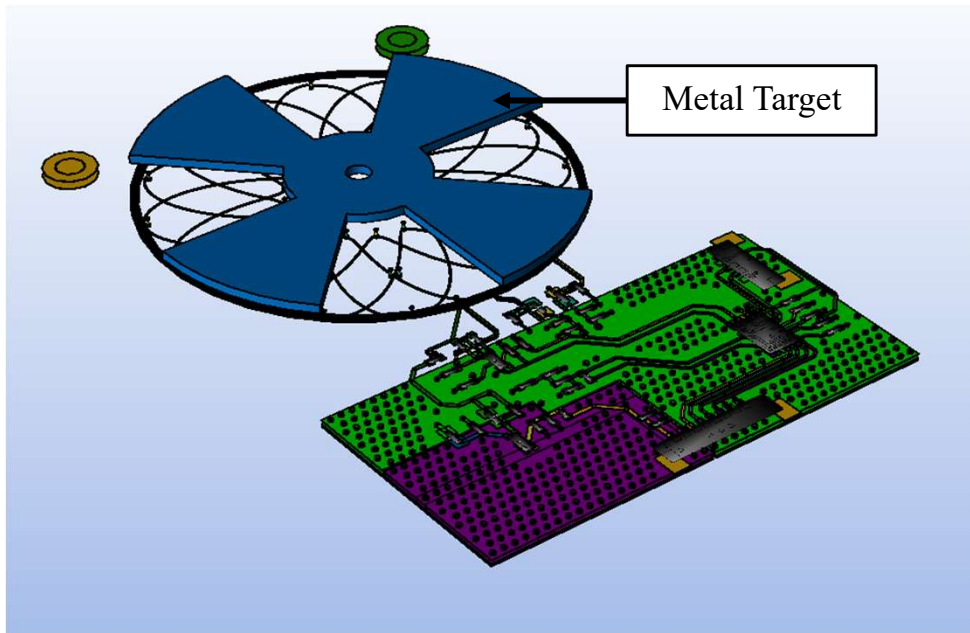

Device Under Test: 90° Rotary Inductive Position Sensor

# Virtual Lab Setup: Cables

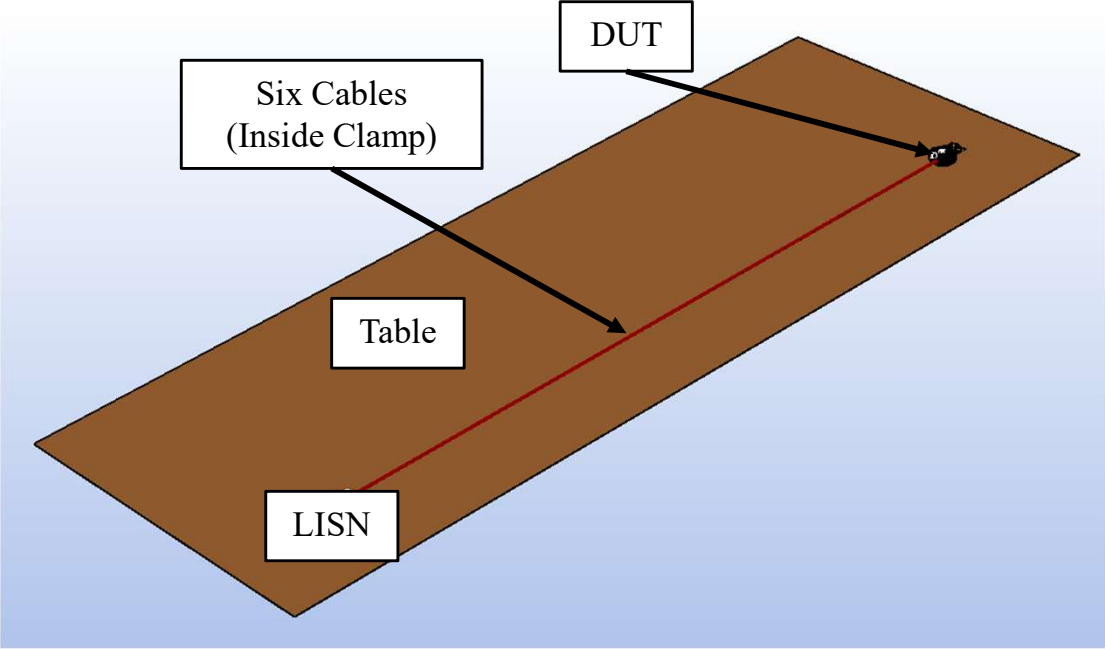

Virtual Lab Setup

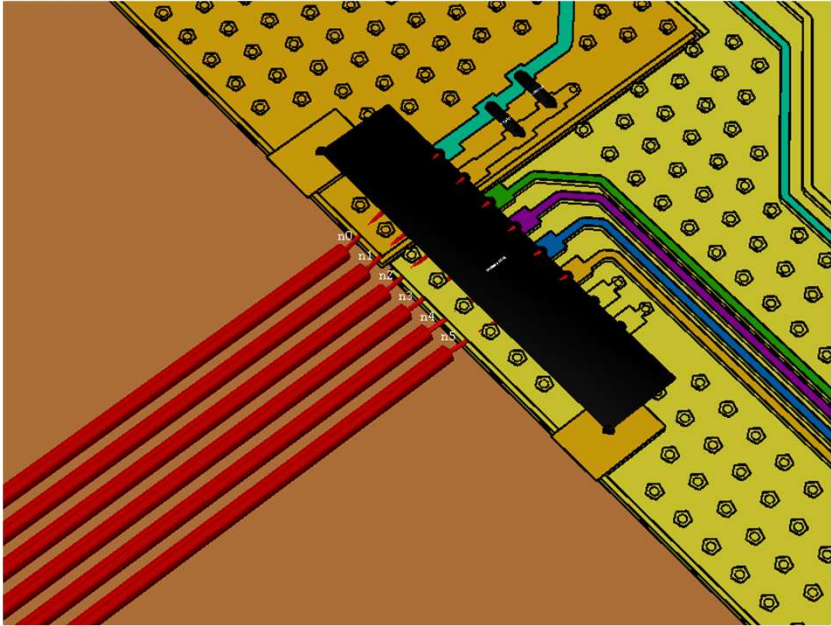

Cables - DUT Connection



# Virtual Lab Setup: Load

- The load for this test consists of,
  - Two LISNs (LISN+ and LISN-)
  - 5V DC Supply
- VIN and GND cable connect to LISN+ and LISN- respectively.
- The 4 signal cables are left open in the virtual lab setup. The lab setup uses a fibre optic optocoupler to study the signals.

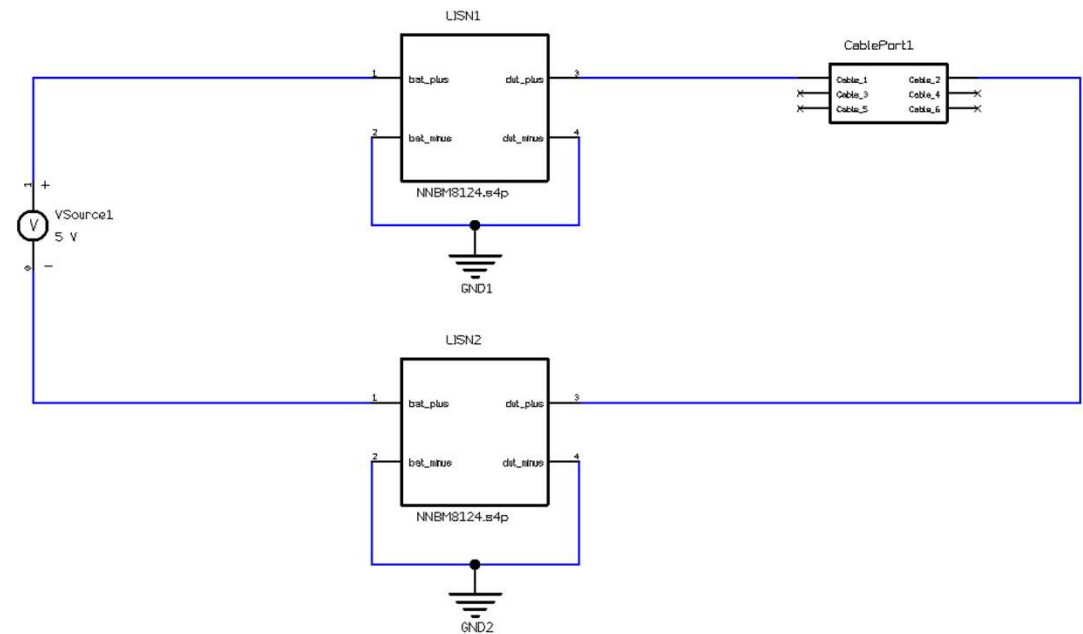

# Result: IC Pin Voltage

- BCI test parameters:
  - Testing Freq.: 1MHz - 400MHz
  - Harness Length: 1700mm
  - Injection Clamp: 150mm
  - BCI test level: Test level 4 (200mA)
- Resonant voltage peaks appear at distinct frequency bands across the BCI range, posing a risk for IC pin failures at these frequencies.

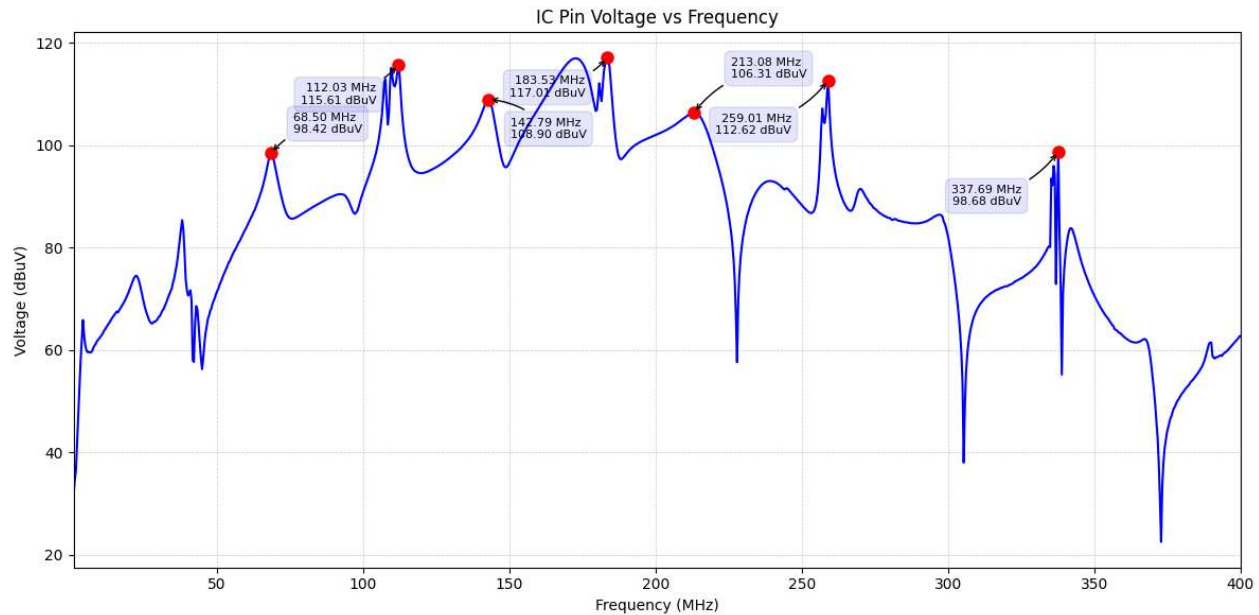

# Result: Failure Correlation

- An IC pin fails when the induced voltage at a given frequency exceeds its specified voltage immunity threshold as defined by the ICIM-IB curve.
- The proposed simulation methodology demonstrates correlation between measured and simulated IC failure events.

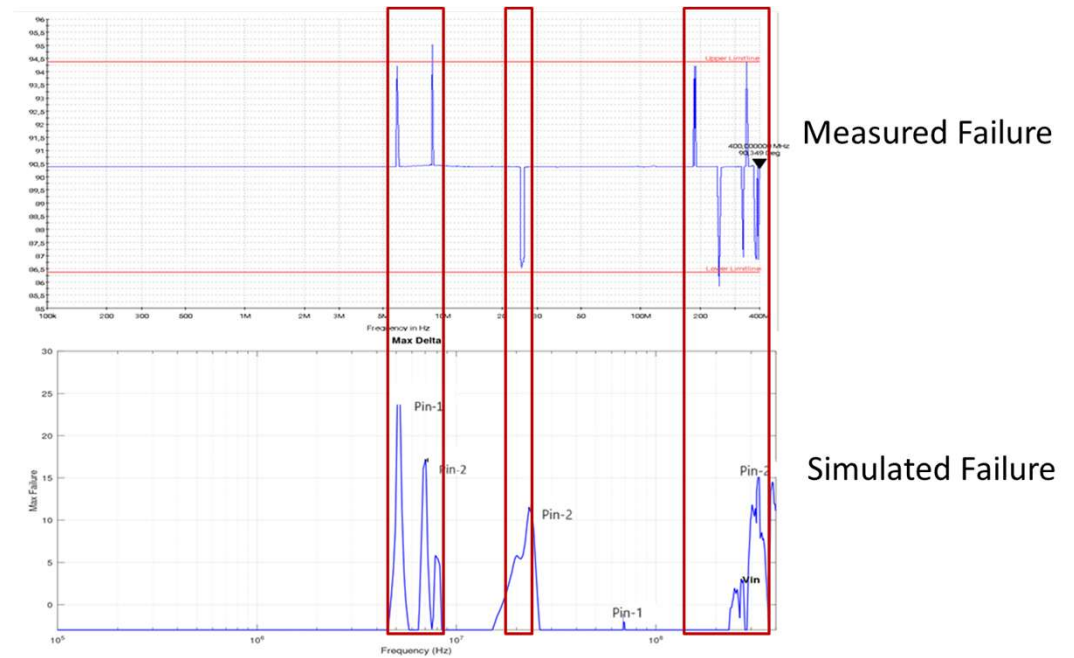
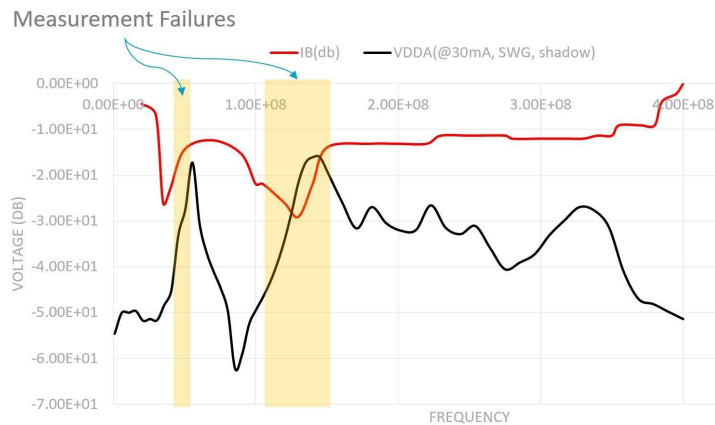

# Diagnosis: Noise Flow

- Common-mode (CM) noise propagates from harness through PCB to primary winding, couples to secondary winding and reaches IC pins.
- Sensor's large physical dimensions create significant capacitance to metal table, enabling strong CM noise coupling path.
- Table - sensor capacitance causes high CM current to flow on sensor winding during BCI.
- Capacitors between sensor winding and PCB ground provide filtering to mitigate this coupled CM noise effectively.

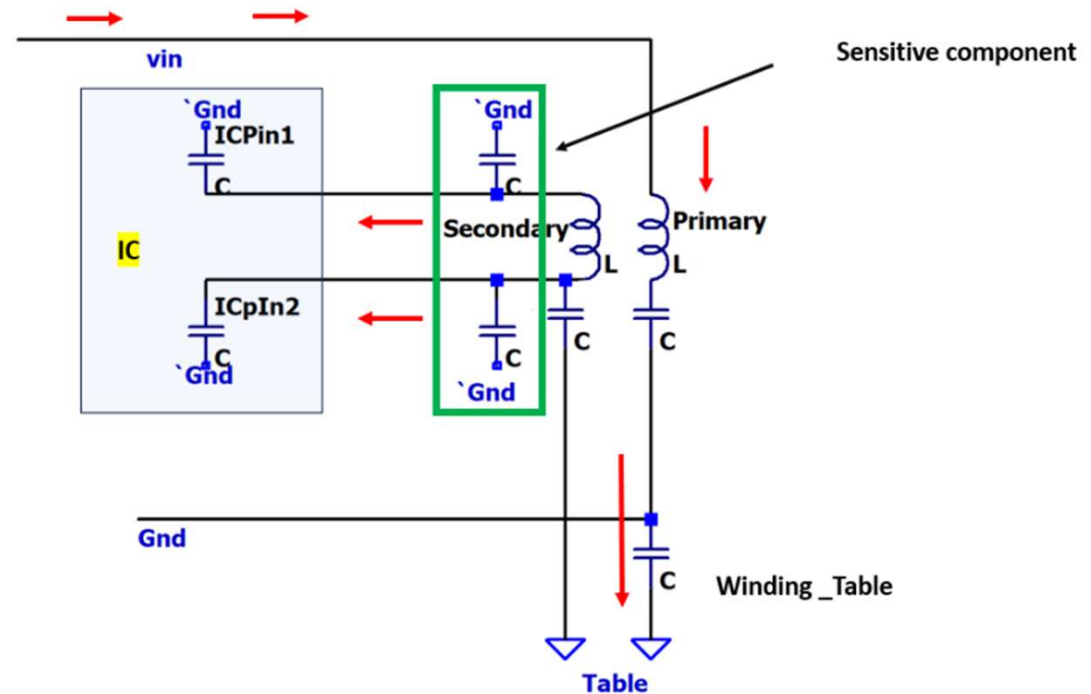

# Diagnosis: Current Density

- Current density simulations were performed at the voltage failure frequencies.
- High current flow is observed along PCB traces directly connected to the cables.
- The RC filter connected to the secondary coil exhibits high current at the failure frequency, indicating a dominant current path.

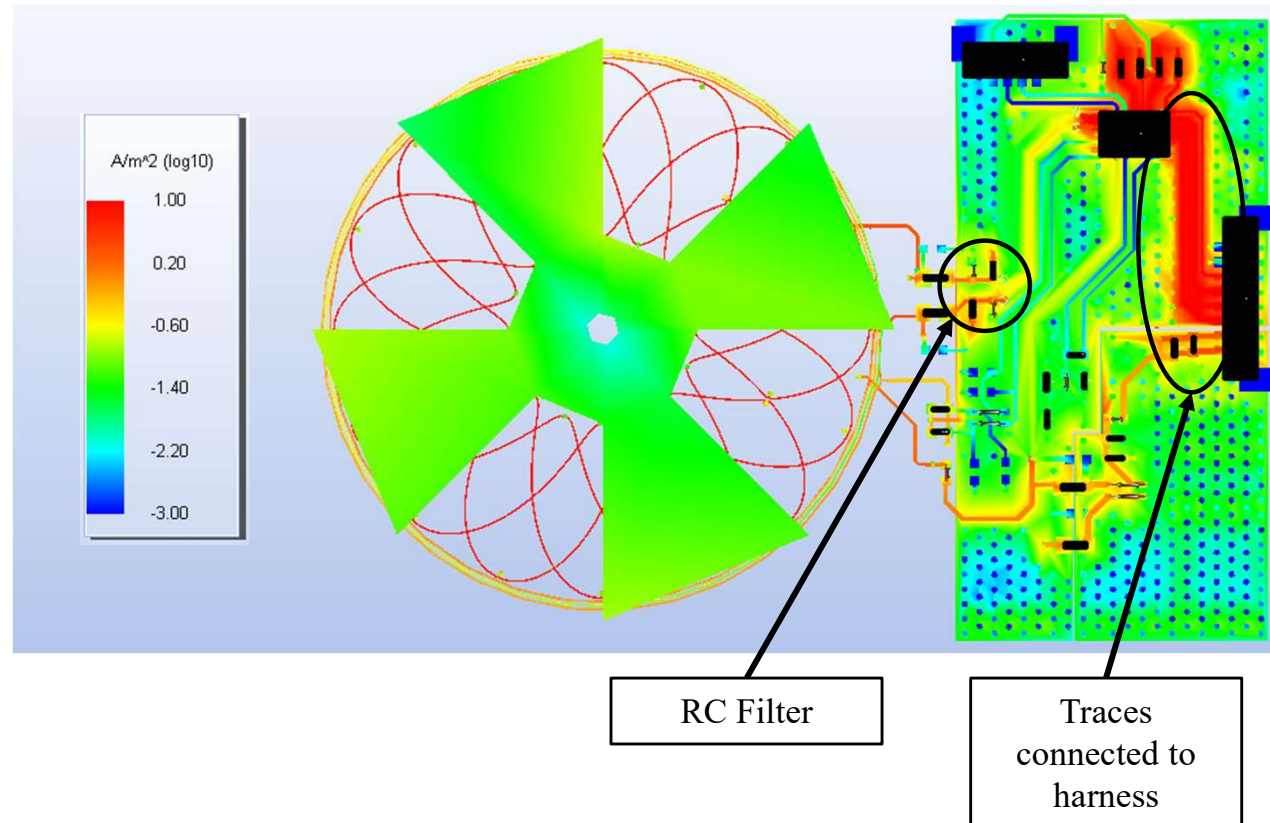

# Diagnosis: Sensitivity Analysis for BCI

- The failure metric  $F(f)$  is defined as the induced differential pin voltage (or ratio to threshold). Then the sensitivity of  $F$  with respect to component  $k$  (say capacitor  $C_k$ ) is,

$$S_k(f) = \frac{\partial F(f)}{\partial C_k}$$

- At each frequency  $f$ , components are ranked by  $|S_k(f)|$ . High sensitivity indicates that small variations in  $C_k$ , significantly influences the induced voltage (hence, failure).
- Component sensitivity varies across the frequency range since different components exhibit sensitivity at distinct frequencies.
- In practice, we apply small perturbations (e.g.  $\pm 10\%$  in  $C_k$ ) in simulation and compute the resulting change in  $F(f)$ . Components with large  $S_k$  are prime candidates for redesign or damping.



# Diagnosis: Sensitivity

- Sensitivity analysis was performed on secondary coil RC filters, primary coil filter, and signal line capacitor; against secondary coil IC pin voltage.
- Voltage variations were ranked and normalized to enable sensitivity comparison across frequency.
- Gradient plot shows C19 (secondary coil RC filter) exhibits highest sensitivity on secondary coil IC pin voltage across BCI frequency band, identifying it as the optimal mitigation component.

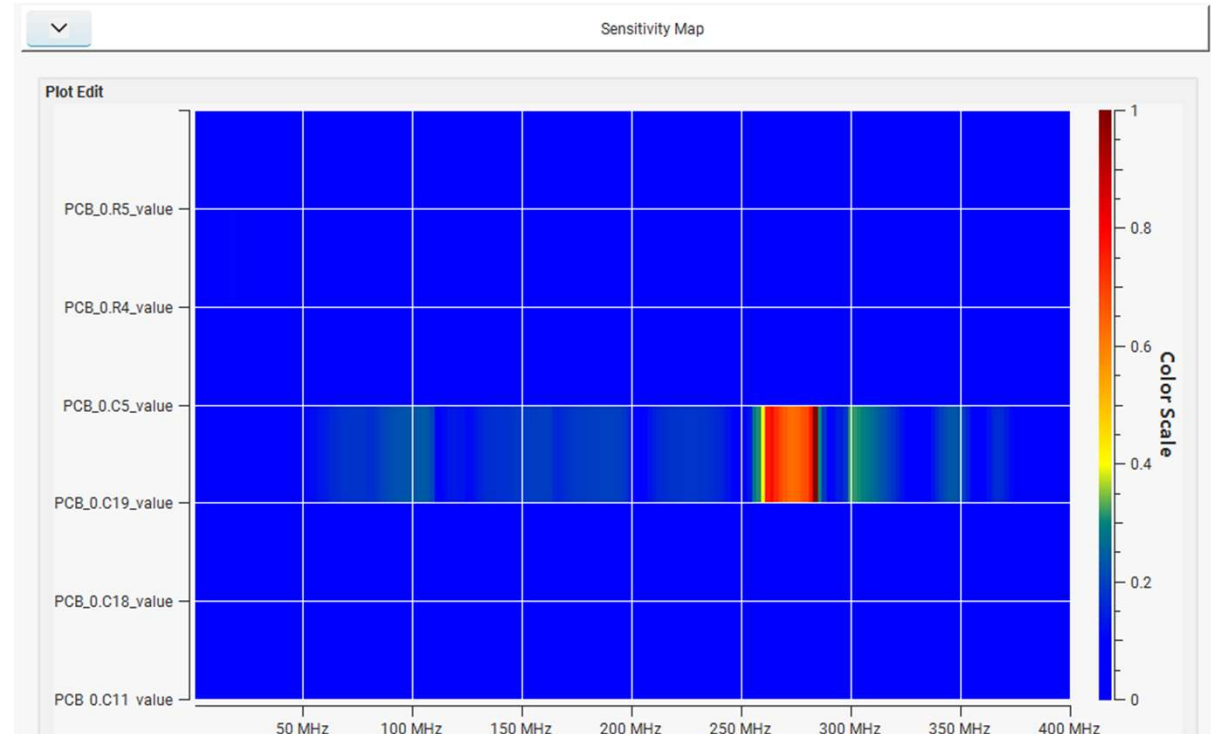

# Diagnosis: What-If? Design Variations

- Sensitivity analysis identifies C19 as the primary tuning parameter for IC pin voltage mitigation.
- What-If analysis varies component values directly without full circuit re-simulation.
- Results show increasing C19 capacitance reduces secondary coil IC pin voltage, preventing failure events.

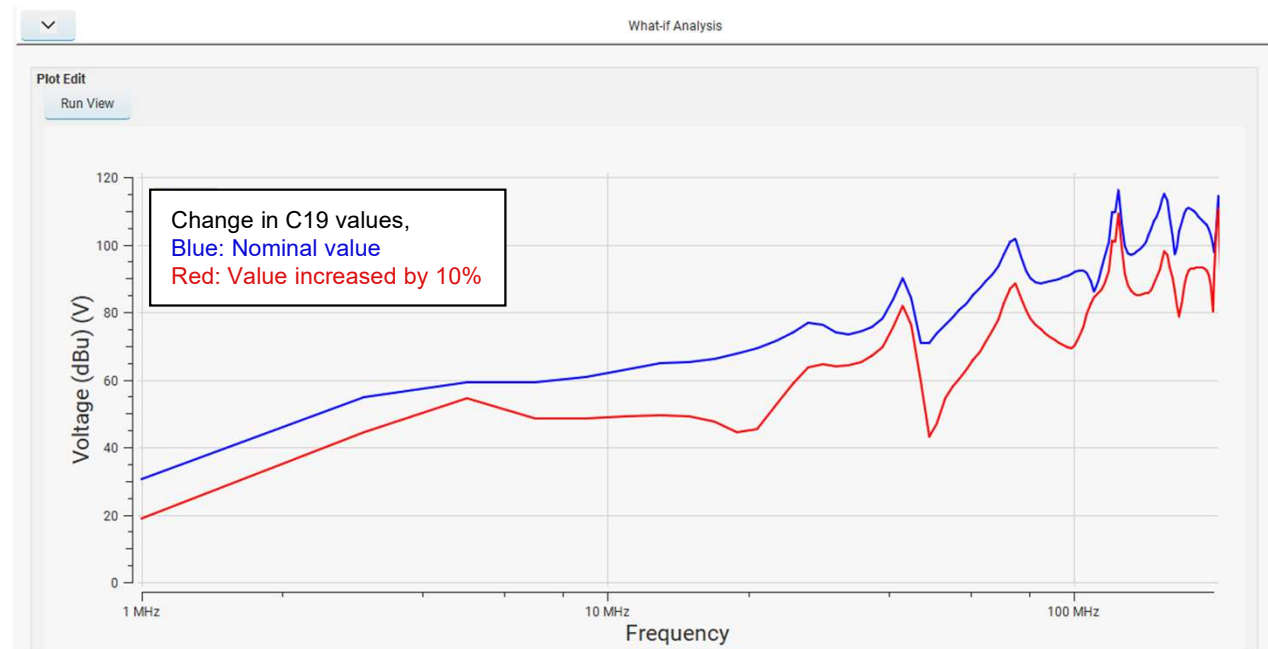

# Conclusion

- A hybrid EM–circuit modeling approach was presented to evaluate and improve IC immunity in inductive position sensor systems.
- Integrating DPI-based IC immunity models into BCI simulations enables system-level prediction of conducted noise susceptibility.
- Sensitivity and What-If analyses identified critical PCB components influencing IC pin voltages.
- Targeted tuning of RC filter components reduced induced IC pin voltages, improving EMC robustness.
- This methodology supports early-stage EMC optimization by predicting and mitigating IC-level failures prior to hardware testing.



# Thank you!

---

## QUESTIONS?

**Bhuvan Sai Lingam**

*Application Engineer, Simyog Technology Pvt. Ltd.*

bhuvan@simyog.com|[simyog.com](http://simyog.com)

